

CLUNE WIND FARM

FIGURE 3.7b

TYPICAL DRAINAGE DETAILS

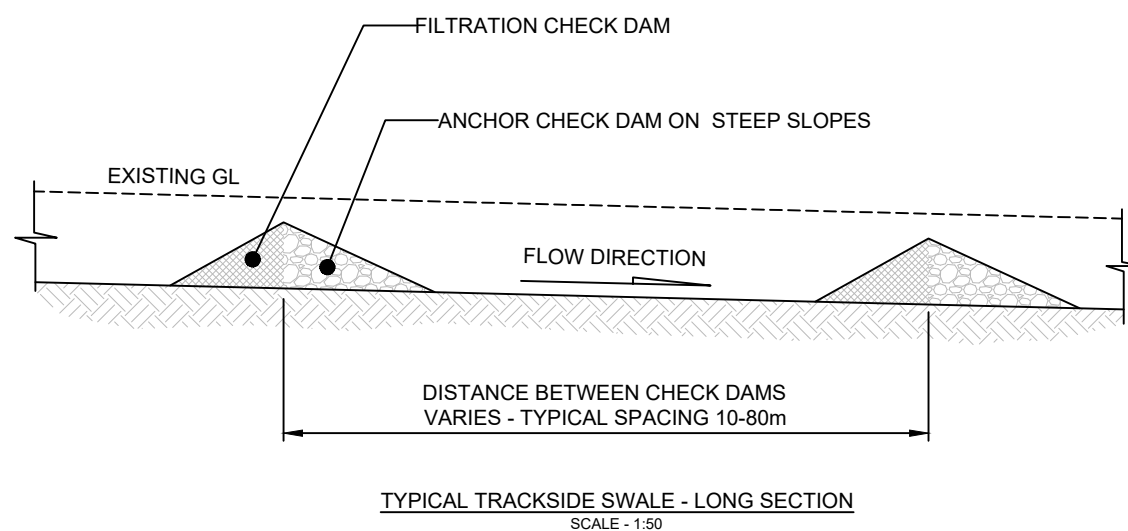
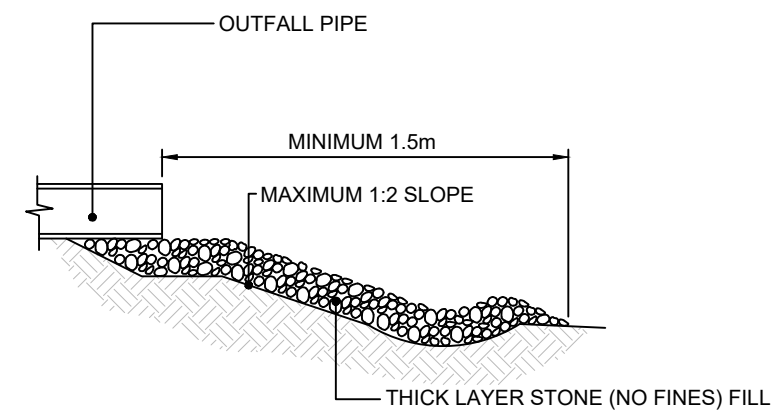
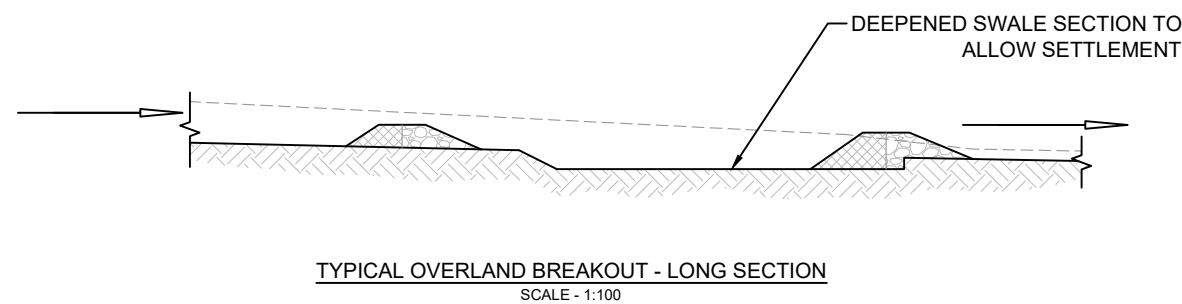
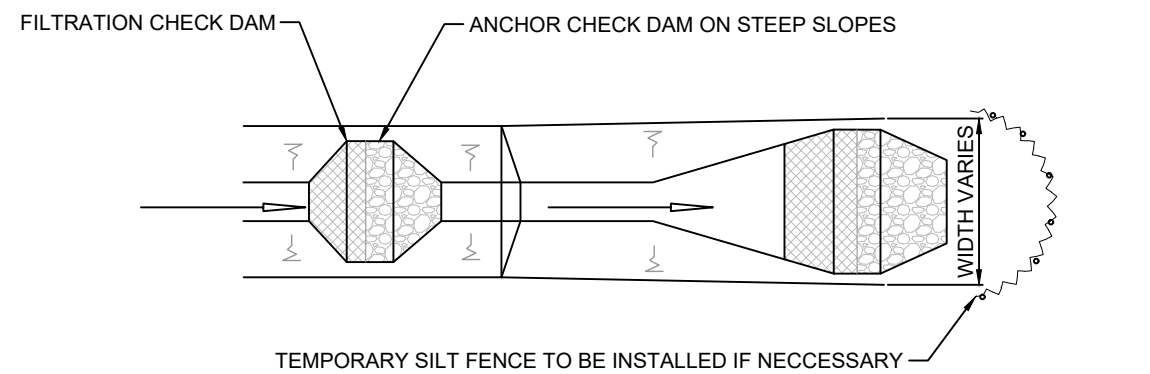
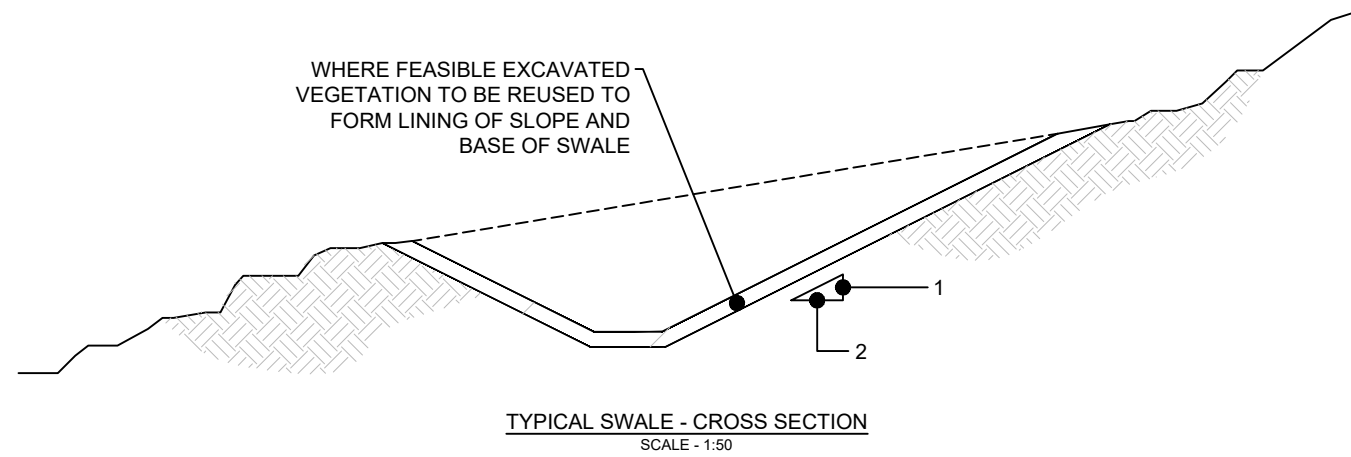

NOTES:

1. SUDS SYSTEM TO BE CONSTRUCTED PRIOR TO, OR AT THE SAME TIME AS THE ACCESS TRACK & HARDSTANDS. INTERIM MEASURES SUCH AS THE PLACEMENT OF SILT FENCES TO BE USED AROUND WATERCOURSES AND RETAINED IN PLACE UNTIL SUDS ARE ESTABLISHED AND PROVIDING SUFFICIENT SILT REMOVAL.
2. THE LEVEL OF SILT IN RUNOFF DURING CONSTRUCTION IS TO BE MONITORED VISUALLY AND EXCESSIVE SILT LEVELS IN ANY AREA TO BE TEMPORARILY MANAGED BY PLACING SILT FENCES AT THE PROBLEM AREAS.
3. WHERE RESEEDING IS REQUIRED, NATIVE SPECIES SEED MIX SHALL BE USED BASED UPON THE SURROUNDING HABITAT. THE PLANTING SHALL BE CAPABLE OF RESISTING DROUGHT CONDITIONS.
4. AREAS STRIPPED OF VEGETATION SHOULD BE KEPT TO A MINIMUM.
5. CLEAN STONE FLOW CONTROL CHECK DAMS TO BE WELL GRADED STONE. AGGREGATE SIZE FOR STONE CHECK DAMS TO BE TYPICALLY 5/40mm CLEAN STONE. ON SLOPING SECTIONS OF THE ACCESS TRACK, 5/40mm CHECK DAMS TO BE PROTECTED FROM WASHING AWAY THROUGH THE PLACEMENT OF 100/150mm STONE ON THE DOWNHILL FACE OF THE CHECK DAM.
6. SILT LEVELS AT CHECK DAMS AND POND FOREBAYS TO BE VISUALLY INSPECTED AS PART OF AN ONGOING MAINTENANCE PROGRAMME DURING THE CONSTRUCTION PHASE. WHERE CHECK DAMS BECOME CLOGGED WITH SILT OR VEGETATION, STONE CHECK DAM TO BE REMOVED AND DISPOSED OF APPROPRIATELY.
7. WHERE ACCESS TRACKS ARE OF FLOATED CONSTRUCTION (OVER PEAT), TRACKSIDE DIRTY WATER SWALES WILL NOT BE PROVIDED.
8. THE REQUIREMENT FOR DIRTY WATER SWALES BOTH SIDES OF TRACK, AND CUT-OFF SWALES WILL VARY TO SUIT THE PROPOSED ACCESS TRACK ALIGNMENT AND EXISTING TOPOGRAPHY.
9. WHERE EROSION IS IDENTIFIED IN THE CUT-OFF SWALES, CHECK DAMS SHOULD BE INSTALLED SIMILAR TO THE TRACKSIDE SWALES WHERE NECESSARY.
10. TYPICAL FILTRATION CHECK DAM CONSIST OF 5-40MM CLEAN DRAINAGE STONE AT UPSTREAM SIDE. TOP OF DAM TO BE FINISHED LEVEL IN SWALE.
11. ALL DIMENSIONS SHOWN ARE INDICATIVE AND SUBJECT TO DETAILED DESIGN.

LAYOUT DWG	N/A	T-LAYOUT NO.	N/A
------------	-----	--------------	-----

DRAWING NUMBER	04707-RES-DRN-DR-CE-002	REV	1
----------------	-------------------------	-----	---

SCALE - AS SHOWN @ A3

ENVIRONMENTAL IMPACT ASSESSMENT REPORT 2024

THIS DRAWING IS THE PROPERTY OF RENEWABLE ENERGY SYSTEMS LTD. AND NO REPRODUCTION MAY BE MADE IN WHOLE OR IN PART WITHOUT PERMISSION